



TECHNICAL PASSPORT OF THE PRODUCT

Polypropylene pipe PP-R PN20

1. Purpose and scope

Raftec "PP-R PN20" pipes - are used in drinking and domestic drinking water systems, hot water supply, as well as as technological pipelines that transport liquids and gases that are not aggressive to the materials of the Raftec pipe and fittings.

PP-R 100 polypropylene pipe. The color of the pipes is gray with a blue stripe and marking.



2. Technical specifications

№	Characteristic	Value					
		RPPN20	RPPN25	RPPN32	RPPN40	RPPN50	RPPN63
1	Article						
2	Outer diameter, mm	20	25	32	40	50	63
3	Inner diameter, mm	13,2	16,6	21,2	26,6	42,0	60,0
4	Wall thickness, mm	3,4	4,2	5,4	6,7	8,4	10,5
5	Normalized pipe series	2,5	2,5	2,5	2,5	2,5	2,5
6	Standard dimensional ratio, SDR	6,0	6,0	6,0	6,0	6,0	6,0
7	Nominal pressure, PN, bar	20	20	20	20	20	20
8	Pipe weight, kg/m.p.	0,166	0,256	0,419	0,639	1,006	1,600
9	PP-R melt flow index, g/10xm	0,3	0,3	0,3	0,3	0,3	0,3
10	Heating time during welding, sec.	5	7	8	12	18	24
11	Welding time, sec.	4	4	6	6	6	6
12	Cooling time after welding, sec.	120	120	220	240	250	360
13	Minimum depth of the pipe socket when welding, mm	14	15	17	18	20	24
14	Internal volume of 1 m.p.,	0,137	0,217	0,353	0,556	0,876	1,385
15	Number of pipes in the package	120m/25pcs /4m	100m/20 pcs/4m	60m/15pcs /4m	40m/10pcs /4m	24m/6pcs/ 4m	16m/4pcs/ 4m
16	Density of PP-R, g/cm ³	0,91					
17	Elongation at break,%	500					
18	Tensile yield strength, MPa	30					

19	Density limit at break, MPa	35
20	Linear expansion coefficient, 1/°C	10x10 ⁻⁵
21	Specific heat capacity, kJ/kg°C	1,73
22	Air permeability, g/m ³ day	<0,1
23	Minimum long-term strength PP-R,MRS, MPA	10
24	Flammability group	G4
25	Flammability group	V3
26	Ability to generate smoke	D3
27	Toxicity of combustion products	T3
28	Mass fraction of volatile substances, %	<0,035

3. Class of operation

Class of operation	Description of the class of operation	Working pressure, bar
1	hot water distribution systems 60°C, service life 50 years	14 bar
2	hot water distribution systems 70°C, service life 50 years	11 bar
4	underfloor heating, low-temperature radiators, service life of 50 years, and it is assumed that (within 50 years) the system will operate for 2.5 years at a temperature of 20°C, 20 years at a temperature of 40°C, 25 years at a temperature of 60°C and 2.5 years at a temperature of 70°C	13 bar
Cold water supply	transportation of cold water at maximum temperature 20 °C	20 bar

4. Installation and operating instructions

1. Installation of polypropylene pipes must be carried out at an ambient temperature of at least +5°C.
2. Connections must be made by thermal polyfusion-coupling welding using a special welding machine. The set operating temperature is 260°C.
3. It is recommended to use the same manufacturer of connecting parts for socket welding as the pipes. In this case, simultaneous heating to the working depth of the pipe and fitting is guaranteed.
4. The heating time when making connections must comply with that set out in the technical specifications.
5. Pipes that have been stored or transported at temperatures below 0 °C must be maintained for 2 years at a temperature not lower than +5 °C before installation.
6. Installation of polypropylene pipe systems should be carried out in accordance with the requirements of current regulatory documents.
7. Pipes must be operated under the conditions specified in the technical characteristics table and under modes corresponding to the accepted operating class.

8. Polypropylene pipes are not allowed to be used:
 - at a working medium temperature above 70°C ;
 - at operating pressure exceeding the permissible value for this class of operation;
 - in premises of categories "A, B, C" according to fire hazard (clause 2.8. SP 40-101-96);
 - in rooms with sources of heat radiation whose surface temperature exceeds 130°C;
 - for expansion, safety, overflow and signal pipelines ;
 - for separate fire water supply systems (clause 1.2. SP40-101-96).

5. Storage and transportation

1. During rail and road transportation, coils (packages) of pipes are allowed to be transported only in covered rolling stock.
2. To avoid damage to the pipes, they should be laid on a flat surface, without sharp protrusions and irregularities. Dropping pipes from vehicles is not allowed..
3. Pipes must be stored in accordance with conditions 5 (OZH4), section 10 of GOST 15150 in ventilated sheds or rooms.
4. Pipe coils may be stored in stacks no higher than 3 m. When stored, pipes must be protected from direct sunlight.
5. The pipe must be stored in the manufacturer's packaging under storage conditions 3 according to GOST 15150-69.
6. Pipe transportation must be carried out in accordance with requirements 5 of GOST 15150-69.

6. Utilization

Disposal of the product (melting, burial, resale) in accordance with the procedure established by the Law of Ukraine of 1992 No. 50, Art. 678, (as amended by No. 2556 - III (2556-14) of 21.06.2001, No. 48, Art. 252 "On Atmospheric Air Protection" (as amended by 14.07.2016), of 1998 No. 36-37, 242 "On Waste" (as amended by 09.04.2015), of 1991 No. 41, Art. 546 "On Environmental Protection" (as amended by 04.10.2016), as well as other norms, acts, rules, orders, etc.

7. Warranty obligations

1. The manufacturer guarantees that the products comply with safety requirements, provided that the consumer complies with the rules of use, transportation, storage, installation and operation.
 2. The warranty covers all defects caused by the manufacturer's fault.
 3. The warranty does not cover defects that occur in the following cases:
 - violation of passport regimes for transportation, storage, installation, operation and maintenance of the product;
 - improper transportation and loading and unloading operations;
 - the presence of traces of exposure to substances that are aggressive to the product materials;
 - the presence of damage caused by fire, natural disasters, force majeure circumstances;
 - the presence of damage caused by incorrect actions of the consumer;
 - the presence of traces of third-party interference in the design of the product.
 4. The manufacturer reserves the right to make changes to the product design that do not affect the declared technical characteristics.
-

8. Warranty terms and conditions

1. Claims for the quality of the goods may be made during the warranty period.
2. Defective products during the warranty period are repaired or exchanged for new ones free of charge. The decision to replace or repair the product is made by the service center. The replaced product or its part obtained as a result of the repair becomes the property of the service center.
3. The costs associated with dismantling, installation and transportation of the defective product during the warranty period are not reimbursed to the Buyer.
4. In cases where the claim is unfounded, the costs of diagnostics and examination are paid by the Buyer.
5. Products are accepted for warranty repair (as well as when returned) fully equipped.

WARRANTY CARD № _____

Product name _____
Brand, article, size _____
Quantity _____
Name and address of the trading organization _____
Date of sale _____ Seller's signature _____

Stamp or seal
of the trading organization

I AGREE with the conditions:
BUYER _____
(signature)

The warranty period is seven years (eighty-four months) from the date of sale to the end consumer.

For warranty repair, complaints and claims regarding the quality of products, please contact the service center at the address: 08132, Kyiv region, Vyshneve, Kyivska st., building 6b.

Tel.: + 38(050)-315-16-33

When making claims regarding the quality of the goods, the buyer shall provide the following documents:

1. A statement in any form, indicating:
 - name of the organization, full name of the buyer, actual address and contact phone number;
 - name and address of the organization that performed the installation;
 - main system parameters;
 - short description of the defect;
2. Document proving the purchase of the product;
3. Hydraulic test certificate of the system in which the product was installed;
4. A completed warranty card issued on the manufacturer's website «raftec.eu».

Return or exchange mark: _____

Date _____ y. Signature: _____



ANNEX A

Thermal expansion of pipes PP-R RAFTEC

The pipeline, under the influence of the temperature difference ΔT , is subject to elongation (or contraction) by the value ΔL .

The formula for calculating elongation is given below:

$$\Delta L = \alpha \times L \times \Delta T$$

where:

α - coefficient of thermal linear elongation (mm/m*K)

0.15 (mm/m*K) – uniform tubes PP

0.05 (mm/m*K) – tubes AI

0.03 (mm/m*K) - tubes Fiberglass

L – length of pipeline section (m)

ΔT - temperature difference during installation and operation (°C)

Example:

Extension of a 25 m section of a homogeneous RAFTEC PN20 pipe, as well as RAFTEC AI and RAFTEC Fiberglass pipes at a temperature difference of 60°C.

- Pipes RAFTEC AI $\Delta L = 0.03 \times 25 \times 60 = 45$ (mm)

- Pipes RAFTEC Fiberglass $0.05 \times 25 \times 60 = 75$ (mm)

- Pipes RAFTEC PN20 $\Delta L = 0.15 \times 25 \times 60 = 225$ (mm)

*Extension of a 25m segment

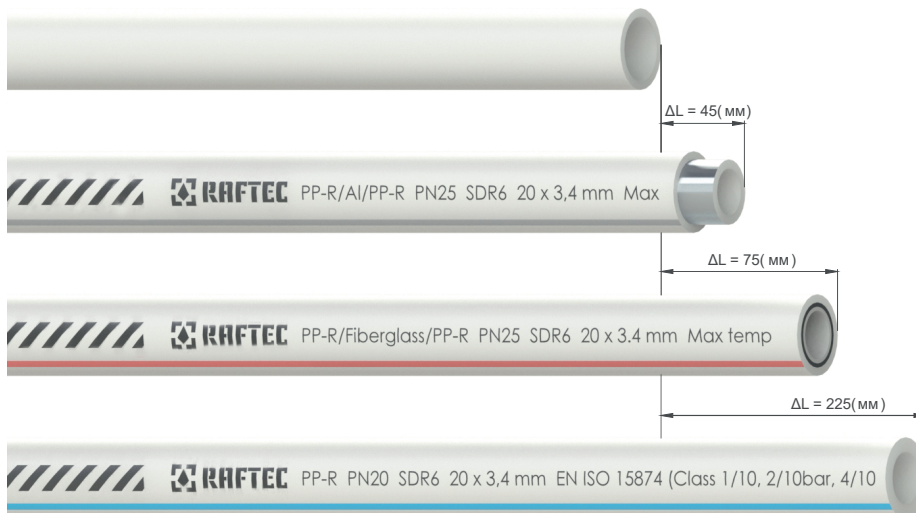

Comparison of thermal elongation of homogeneous and combined pipes PN20, AI, Fiberglass RAFTEC PPR

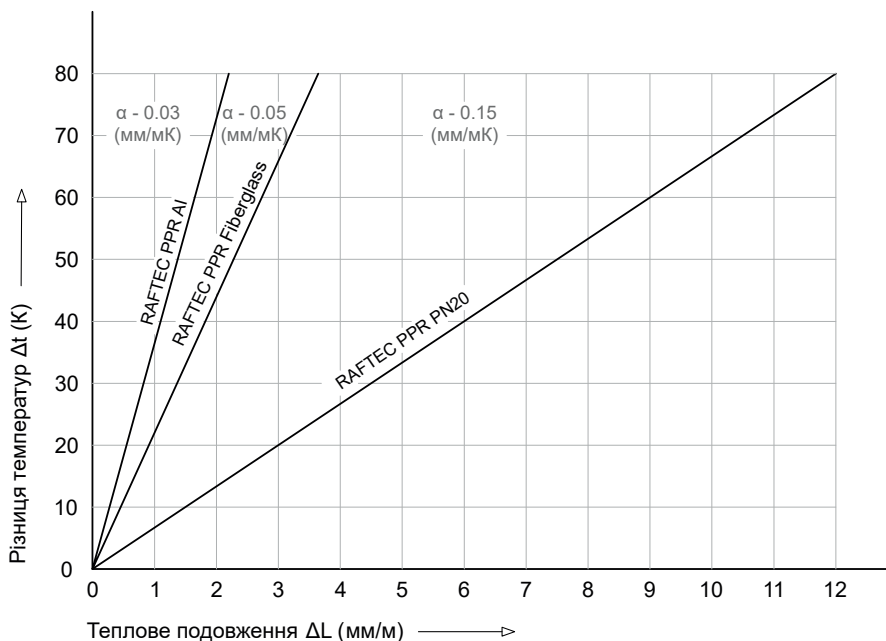

Compensation for extensions

In order to eliminate the consequences of pipeline elongation (uncontrolled pipeline movements and their deformation), various compensation options are used (flexible compensation arms, as well as U- and Z-shaped compensators).

$$L_s = K \times \sqrt{D_{30B} \times \Delta L}$$

where:

L_s - length of the compensation arm (mm)

K - dimensionless material constant = 20

D_{ext} - outer diameter of the pipe (mm)

ΔL - linear extension of the pipeline (mm)

Selection of G, S, U-shaped compensators

Table 1 Required length of the compensation arm A (mm) for RAFTEC PPR

Lengthening ΔL (mm)	Outer diameter of the pipe d_{30B} (MM)					
	20	25	32	40	50	63
	Required length of the compensation arm A (mm)					
2	126	141	160	179	200	225
4	179	200	226	253	283	318
6	219	145	277	310	346	389
8	253	283	320	358	400	449
10	283	316	358	400	447	502
12	310	346	392	438	490	550
14	335	374	423	473	529	594
16	358	400	453	506	566	635
18	379	424	480	537	600	674
20	400	447	506	566	632	710
22	420	469	531	593	663	745
24	438	490	554	620	693	778
26	456	510	577	645	721	809
28	473	529	599	669	748	840
30	490	548	620	693	775	869
32	506	566	640	716	800	898
34	522	583	660	738	825	926

Table 1 shows the required length of the compensation arm for different values of elongation ΔL and pipe outer diameter d_{out} .

The principle of selecting compensators of various types:

1. Γ- similar compensator

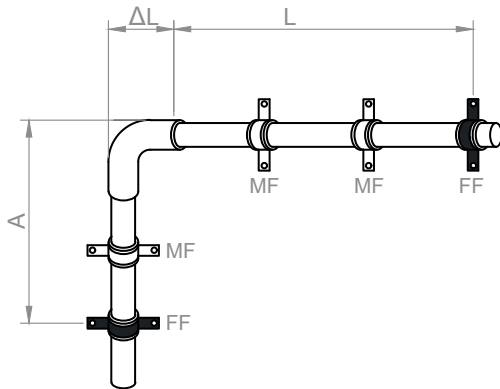

FF - Fixed fixture
 MF - Movable fixture
 L - Initial pipeline length
 A - Length of compensation arm
 ΔL - Pipeline elongation

To calculate the compensation arm A, it is necessary to take the equivalent length $L_e=L$ and for this length determine the elongation value ΔL , and then find the length of the compensation arm A according to table 1

2. S- similar compensator

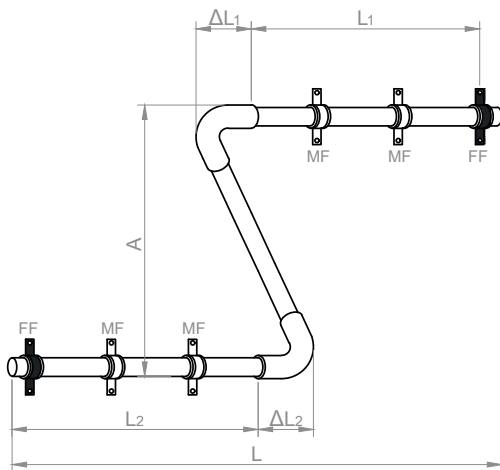

FF - Fixed fixture
 MF - Movable fixture
 L - Initial pipeline length
 A - Length of compensation arm
 ΔL - Pipeline elongation

To calculate the compensation arm A, it is necessary to take the equivalent length L_e as the sum of L_1 and L_2 : $L_e=L_1+L_2$ and for this length determine the equivalent elongation ΔL , and then find the length of the compensation arm A according to table 1

3. Π- similar compensator

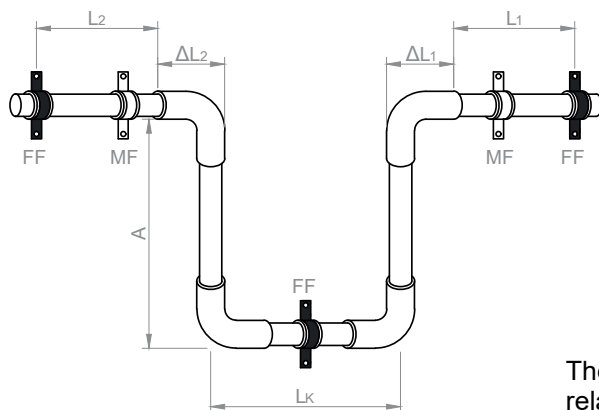

FF - Fixed fixture
 MF - Movable fixture
 L - Initial pipeline length
 A - Length of the compensation arm
 ΔL - Pipeline extension
 L_k - Compensator width

The width L_k of the compensator is calculated from the relationship: $L_k=A/2$

In case of placing the fixed support point PC on the segment, which is the width of the compensator L_k , to calculate the compensation arm A, it is necessary to take the equivalent length L_e as the greater of the values L_1 and L_2 : $L_e = \max(L_1, L_2)$ and for this length find the equivalent elongation ΔL , and then the length of the compensation arm A according to Table 1

Polyfusion welding PPR

Welding temperature for PPR: $260 \pm 10^{\circ}\text{C}$
 Minimum ambient temperature $+5^{\circ}\text{C}$

№	Diameter, mm	Heating, sec.	Connection, sec	Cooling time, min
1	20	5	4	2
2	25	7	4	3
3	32	8	6	4
4	40	12	6	4
5	50	18	6	5
6	63	24	8	6

WARNING.

The installed network can be filled with water no earlier than an hour after the last welded joint is made.

Standard compensation loop application table

Ø pipes (mm)	Distance between fixed supports L(m)	
	Al, Fiberglass	PPR
20	27	9
25	30	10
32	36	12
40	42	14

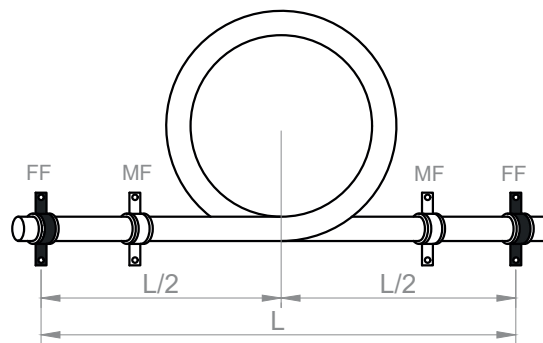

Rules for mounting supports

Example of a fixed support point

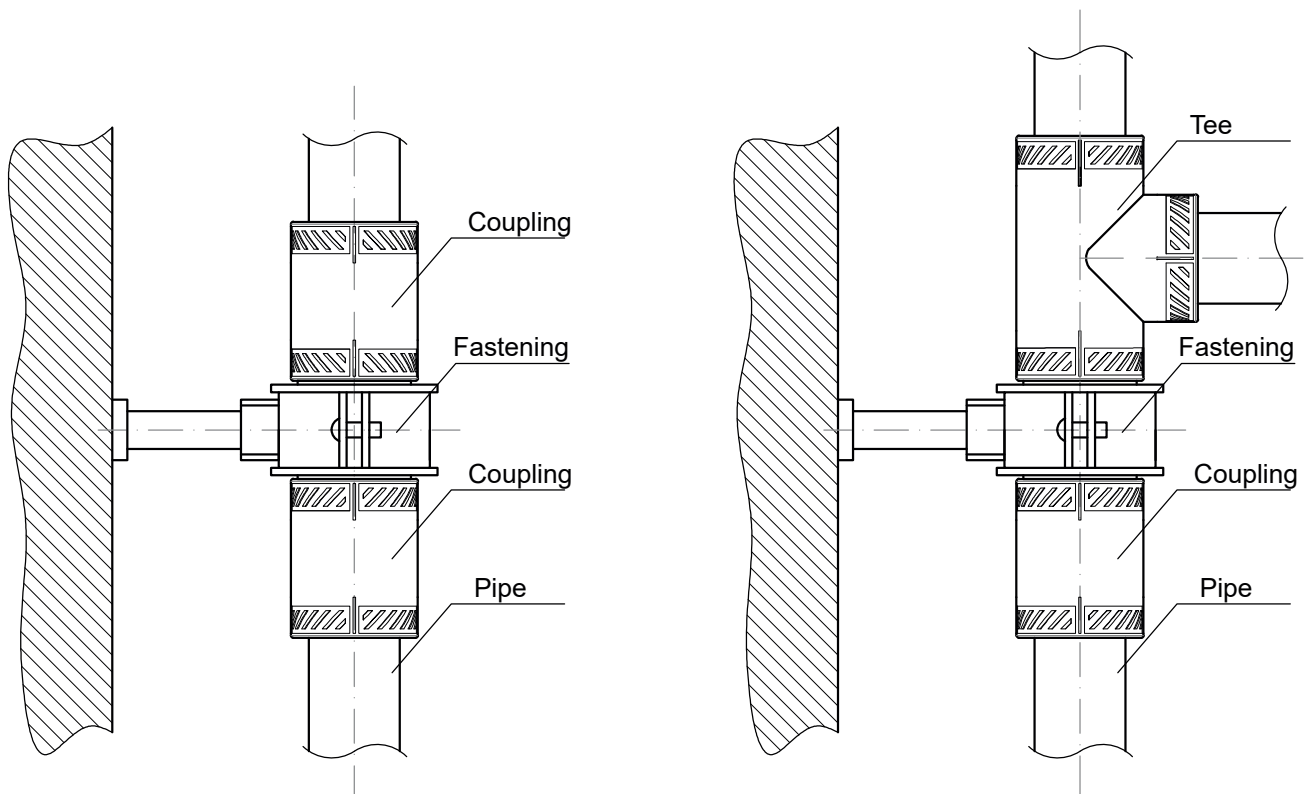

Examples of laying risers of a hot water supply system depending on the type of pipes

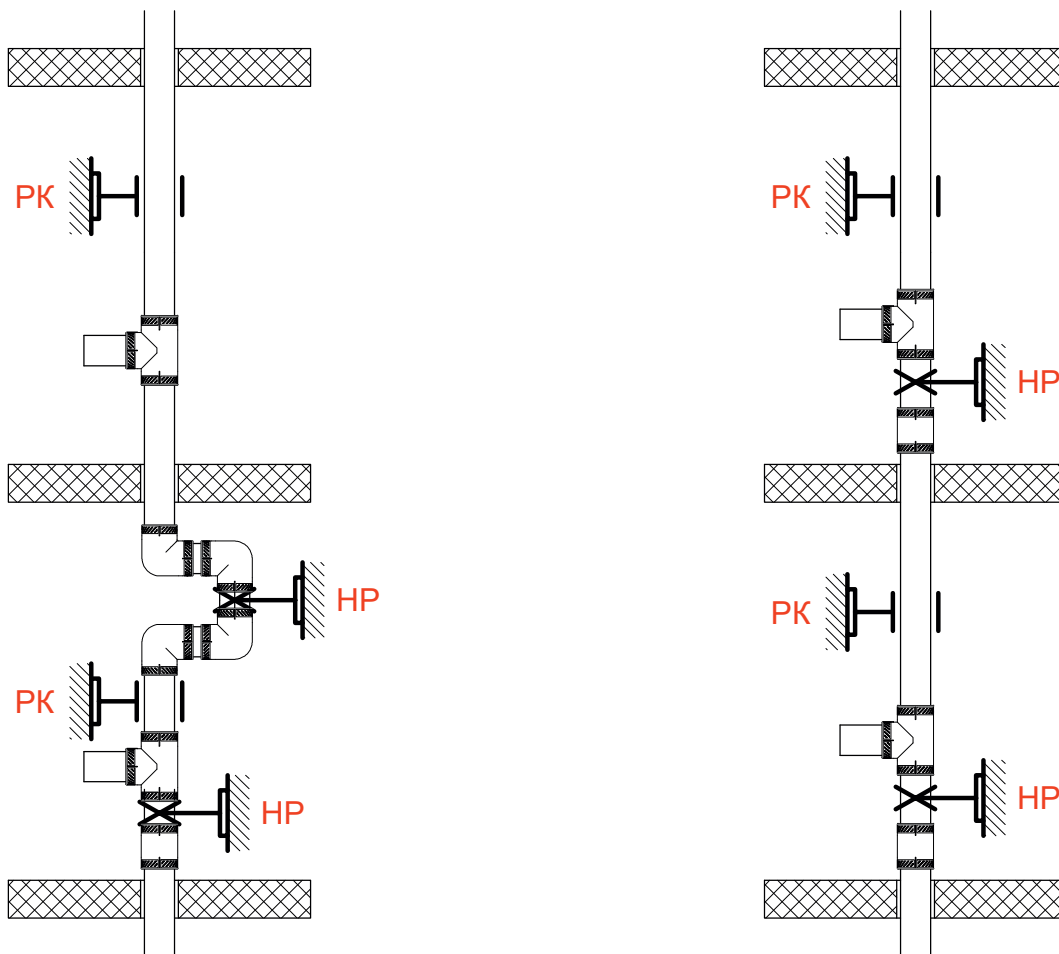

Pipe type
PN20
Horizontal pipeline

Ø pipes (mm)	Distance between fasteners (cm), horizontal pipeline at water temperature					
	20°	30°	40°	50°	60°	70°
20	60	60	60	60	55	50
25	70	70	65	65	60	60
32	90	90	80	80	75	70
40	100	100	90	90	85	80
50	120	120	110	110	100	95
63	140	140	130	130	115	105

For vertical pipelines, the distance between supports can be increased by 30%.

Pipe type
Al
Horizontal pipeline

Ø pipes (mm)	Distance between fasteners (cm), horizontal pipeline at water temperature					
	20°	30°	40°	50°	60°	70°
20	120	120	110	110	100	90
25	130	130	120	120	110	100
32	150	150	140	140	130	120
40	170	170	160	160	150	140
50	190	190	180	180	170	160
63	210	210	200	200	190	180

For vertical pipelines, the distance between supports can be increased by 30%.

Pipe type
Fiberglass
Horizontal pipeline

Ø pipes (mm)	Distance between fasteners (cm), horizontal pipeline at water temperature					
	20°	30°	40°	50°	60°	70°
20	90	90	85	85	80	70
25	105	105	95	95	90	80
32	120	120	110	110	105	95
40	135	135	125	125	120	110
50	155	155	145	145	135	130
63	175	175	165	165	155	145

For vertical pipelines, the distance between supports can be increased by 30%.