



TECHNICAL DATA SHEET OF THE PRODUCT

Pipe clamp

1. Purpose and scope of application

The pipe clamp allows you to securely attach pipelines to the supporting surface. The fastening design guarantees reliable fixation, prevents the pipe from falling out under various operating conditions of the system, and changes in the geometric dimensions of its elements due to thermal linear expansion. Raftec brackets are made of high-quality material, allowing use in various conditions.

2. Technical specifications

№	Characteristic	Designation
1	Purpose	For fastening pipes
2	Heat resistance	up to 120°C
3	Dowel, mm	10x50
4	Clamp material	Stainless steel
5	Gasket material	EPDM

3. Nomenclature and overall dimensions

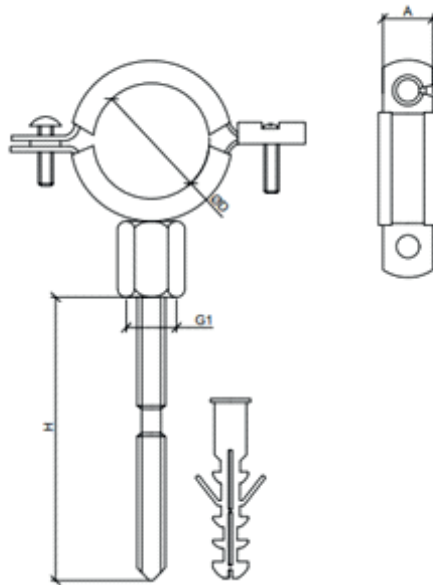

Pipe clamp					
Size	Article	G1	D, mm.	A, mm.	H, mm.
3/8"	RHO-1519	M8	15-19	20	80
1/2"	RHO-2025	M8	20-25	20	80
3/4"	RHO-2630	M8	26-30	20	80
1"	RHO-3236	M8	32-36	20	80
1 1/4"	RHO-3843	M8	38-43	20	80
1 1/2"	RHO-4751	M8	47-51	20	100
2"	RHO-6064	M10	60-64	20	100
2 1/2"	RHO-7580	M10	75-80	20	100
3"	RHO-8792	M10	87-92	20	100
3 1/2"	RHO-99105	M10	99-105	20	100
4"	RHO-113118	M10	113-118	20	100
6"	RHO-159166	M10	159-166	20	100

4. Warranty obligations

1. The manufacturer guarantees that the products comply with safety requirements, provided that the consumer complies with the rules of use, transportation, storage, installation and operation.
2. The warranty covers all defects caused by the manufacturer's fault.
3. The warranty does not cover defects that occur in the following cases:
 - violation of passport regimes for transportation, storage, installation, operation and maintenance of the product;
 - improper transportation and loading and unloading operations;
 - the presence of traces of exposure to substances that are aggressive to the product materials;
 - the presence of damage caused by fire, natural disasters, force majeure circumstances;
 - the presence of damage caused by incorrect actions of the consumer;
 - the presence of traces of third-party interference in the design of the product.
4. The manufacturer reserves the right to make changes to the product design that do not affect the declared technical characteristics.

5. Warranty terms and conditions

1. Claims for the quality of the goods may be made during the warranty period.
 2. Defective products during the warranty period are repaired or exchanged for new ones free of charge. The decision to replace or repair the product is made by the service center. The replaced product or its part obtained as a result of the repair becomes the property of the service center.
 3. The costs associated with dismantling, installation and transportation of the defective product during the warranty period are not reimbursed to the Buyer.
 4. In cases where the claim is unfounded, the costs of diagnostics and examination are paid by the Buyer.
 5. Products are accepted for warranty repair (as well as when returned) fully equipped.
-

WARRANTY CARD № _____

Product name _____

Brand, article, size _____

Quantity _____

Name and address of the trading organization _____

Date of sale _____ Seller's signature _____

Stamp or seal
of the trading organizationI AGREE with the conditions:
BUYER _____
(signature)

The warranty period is seven years (eighty-four months) from the date of sale to the end consumer.

When making claims regarding the quality of the goods, the buyer shall provide the following documents:

1. A statement in any form, indicating:
 - name of the organization, full name of the buyer, actual address and contact phone number;
 - name and address of the organization that performed the installation;
 - main system parameters;
 - short description of the defect;
2. Document proving the purchase of the product;
3. Hydraulic test certificate of the system in which the product was installed;
4. A completed warranty card issued on the manufacturer's website «raftec.eu».

Return or exchange mark: _____

Date _____ y. Signature: _____
