



TECHNICAL DATA SHEET OF THE PRODUCT

Non-return check valve metal shutter

1. Purpose and scope of application

A check valve is a type of safety valve used to ensure the flow of liquids or gases through pipelines in one direction, as well as to protect pipelines, pumps, pressure vessels and to protect systems from leaks when individual components are destroyed.

Applications of a check valve:

1. Centralized water supply system. The mechanism protects measuring instruments from water hammer and prevents water from flowing back in the event of pressure surges.

2. Autonomous water supply systems (wells). Water is supplied using a submersible pump, which lifts it to the surface and supplies it through pipes. The check valve prevents water from flowing back into the well when the pump is turned off.

3. Autonomous heating system. If the system has several heating circuits with different pressure and hydraulic parameters, the check valve acts as a shut-off mechanism to normalize all values. Protects boiler and pump equipment from backflow.

The NRVF series valve is used for installation in front of deep well or borehole pumps.

2. Technical specifications

№	Characteristic	Designation
		1"
1	Connecting thread	Pipe inch
2	Nominal pressure, PN, bar	40
3	Minimum working pressure, bar	0,05
4	Operating temperature of liquid, °C	from 0 to 120°C
5	Working environment temperature, °C	from -20 to 130°C
6	Average full service life, years	15

3. Construction and materials

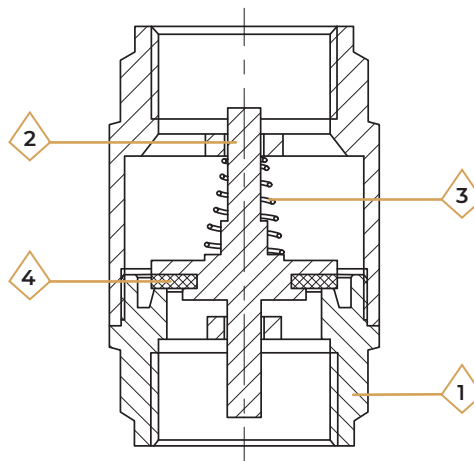

№	Element name	Material	Material grade according to standards
1	Crane body	Hot pressed brass nickel plated	CW617N
2	Stock	Hot pressed brass nickel plated	CW617N
3	Spring	Stainless steel	AISI 316
4	Gasket	Ethylene-propylene-diene monomer	EPDM

4. Nomenclature and overall dimensions

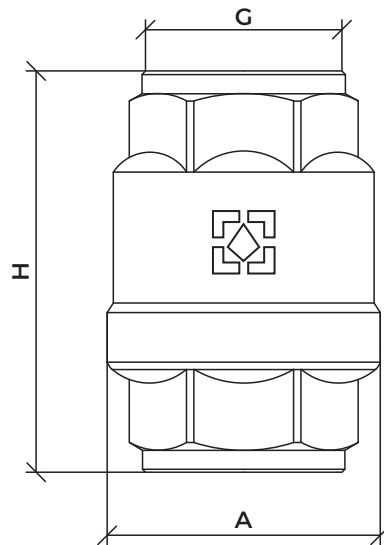

Non-return check valve metal shutter FF					
Size	Article	G	A, mm.	H, mm.	Weight, gr.
1"	NRVF03	1/2"	48	74,5	420

5. Operating and maintenance instructions

1. Check valves must be operated under the conditions specified in the tables listed in Section No. 2 "Technical Specifications".
2. The installation of the check valve must be carried out following the steps from section No. 5 "Installation instructions".

6. Installation instructions

1. Installation can be performed by a specialist or a specialized organization.
2. The installation of connectors should be carried out in accordance with the requirements of SP 73.13330.2012 "Internal sanitary and technical systems". The valve can be installed both horizontally and vertically, and the arrow on the body must match the direction of the flow of the transported medium.
3. The valve must not be subject to loads from the pipeline (bending, compression, stretching, torsion, distortion, vibration, misalignment of pipes, uneven tightening of fasteners).
4. If necessary, supports or compensators must be provided to reduce the load on the valve from the pipeline.
5. The misalignment of the connected pipelines must not exceed 3 mm for a length of up to 1 m + 1 mm for each subsequent meter.
6. After installation, the system units must be tested for tightness using hydraulic or pneumatic methods.
7. As a sealant for threaded connections, it is necessary to use FUM tape (fluoroplastic sealant), polyamide thread with silicone, flax with special pastes, as well as other sealing materials that ensure the tightness of the connections.
8. When installing check valves, the torque specified in the table must not be exceeded:

Nominal bore in inches	1/2"	3/4"	1"	1 1/4"	1 1/2"	2"
Torque, Nm	35	45	65	90	130	160

7. Warranty obligations

1. The manufacturer guarantees that the products comply with safety requirements, provided that the consumer complies with the rules of use, transportation, storage, installation and operation.
2. The warranty covers all defects caused by the manufacturer's fault.
3. The warranty does not cover defects that occur in the following cases:
 - violation of passport regimes for transportation, storage, installation, operation and maintenance of the product;
 - improper transportation and loading and unloading operations;
 - the presence of traces of exposure to substances that are aggressive to the product materials;
 - the presence of damage caused by fire, natural disasters, force majeure circumstances;
 - the presence of damage caused by incorrect actions of the consumer;
 - the presence of traces of third-party interference in the design of the product.
4. The manufacturer reserves the right to make changes to the product design that do not affect the declared technical characteristics.

8. Warranty terms and conditions

1. Claims for the quality of the goods may be made during the warranty period.
 2. Defective products during the warranty period are repaired or exchanged for new ones free of charge. The decision to replace or repair the product is made by the service center. The replaced product or its part obtained as a result of the repair becomes the property of the service center.
 3. The costs associated with dismantling, installation and transportation of the defective product during the warranty period are not reimbursed to the Buyer.
 4. In cases where the claim is unfounded, the costs of diagnostics and examination are paid by the Buyer.
 5. Products are accepted for warranty repair (as well as when returned) fully equipped.
-

WARRANTY CARD № _____

Product name _____

Brand, article, size _____

Quantity _____

Name and address of the trading organization _____

Date of sale _____ Seller's signature _____

Stamp or seal
of the trading organizationI AGREE with the conditions:
BUYER _____
(signature)

The warranty period is seven years (eighty-four months) from the date of sale to the end consumer.

When making claims regarding the quality of the goods, the buyer shall provide the following documents:

1. A statement in any form, indicating:
 - name of the organization, full name of the buyer, actual address and contact phone number;
 - name and address of the organization that performed the installation;
 - main system parameters;
 - short description of the defect;
2. Document proving the purchase of the product;
3. Hydraulic test certificate of the system in which the product was installed;
4. A completed warranty card issued on the manufacturer's website «raftec.eu».

Return or exchange mark: _____

Date _____ y. Signature: _____
